

CATALOG NUMBER	DESCRIPTION	APPROX. WT.	STANDARD PACK
PTC2	FOR USE ON "D" DIE AC'S OR ANY H-FRAME CONNECTORS UP TO 2 1/2" LONG, VCP-43A, VCP-44 VAC-1040 AND VAC-4040	.070 [0.03]	100

ITEM	DESCRIPTION	MATERIAL
1	SNAP TAP™ PLASTIC COVER	BLACK PLASTIC

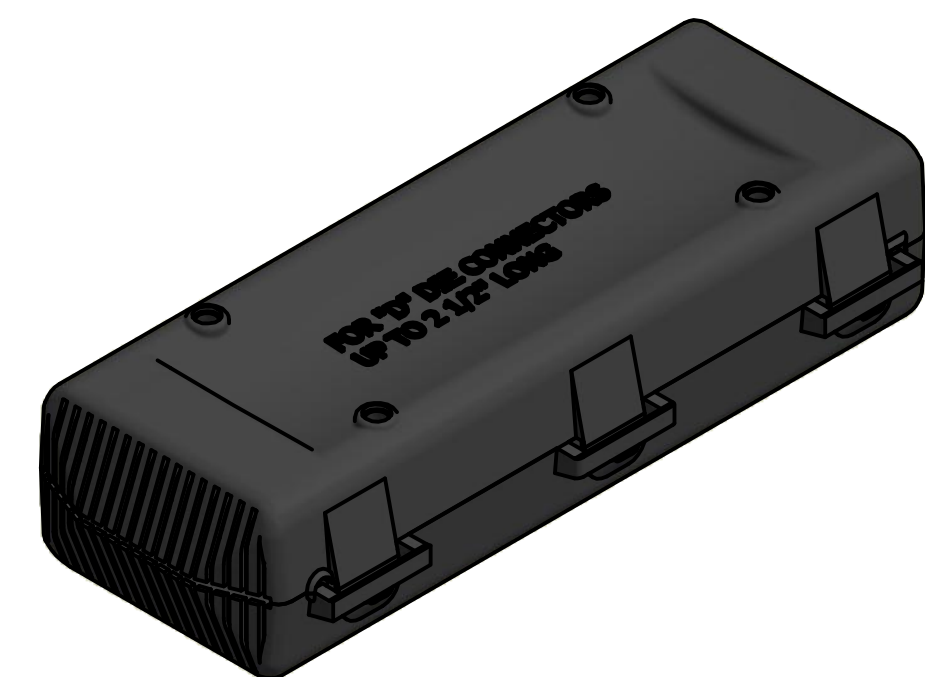
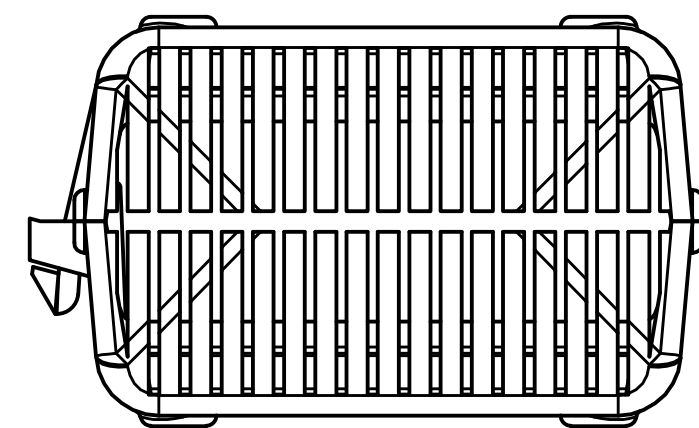
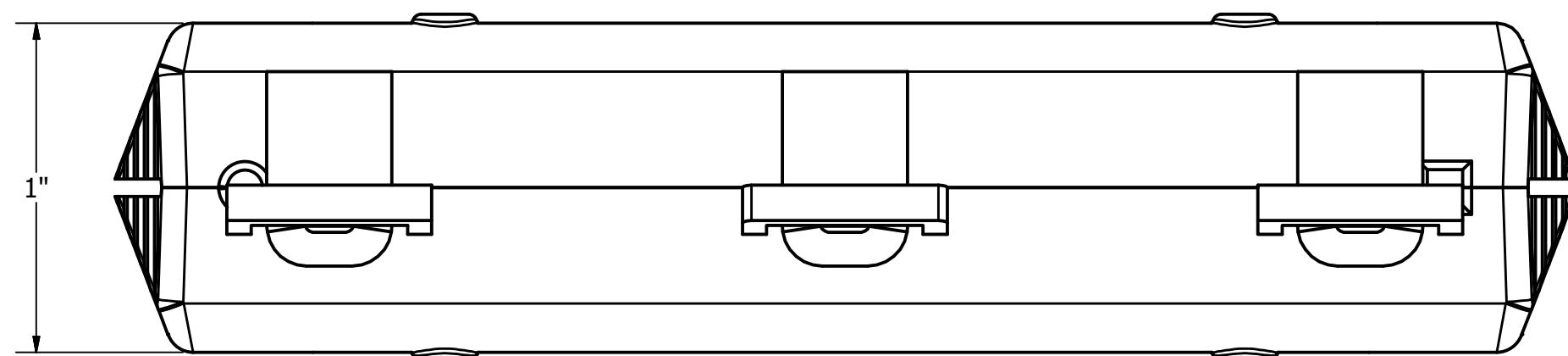
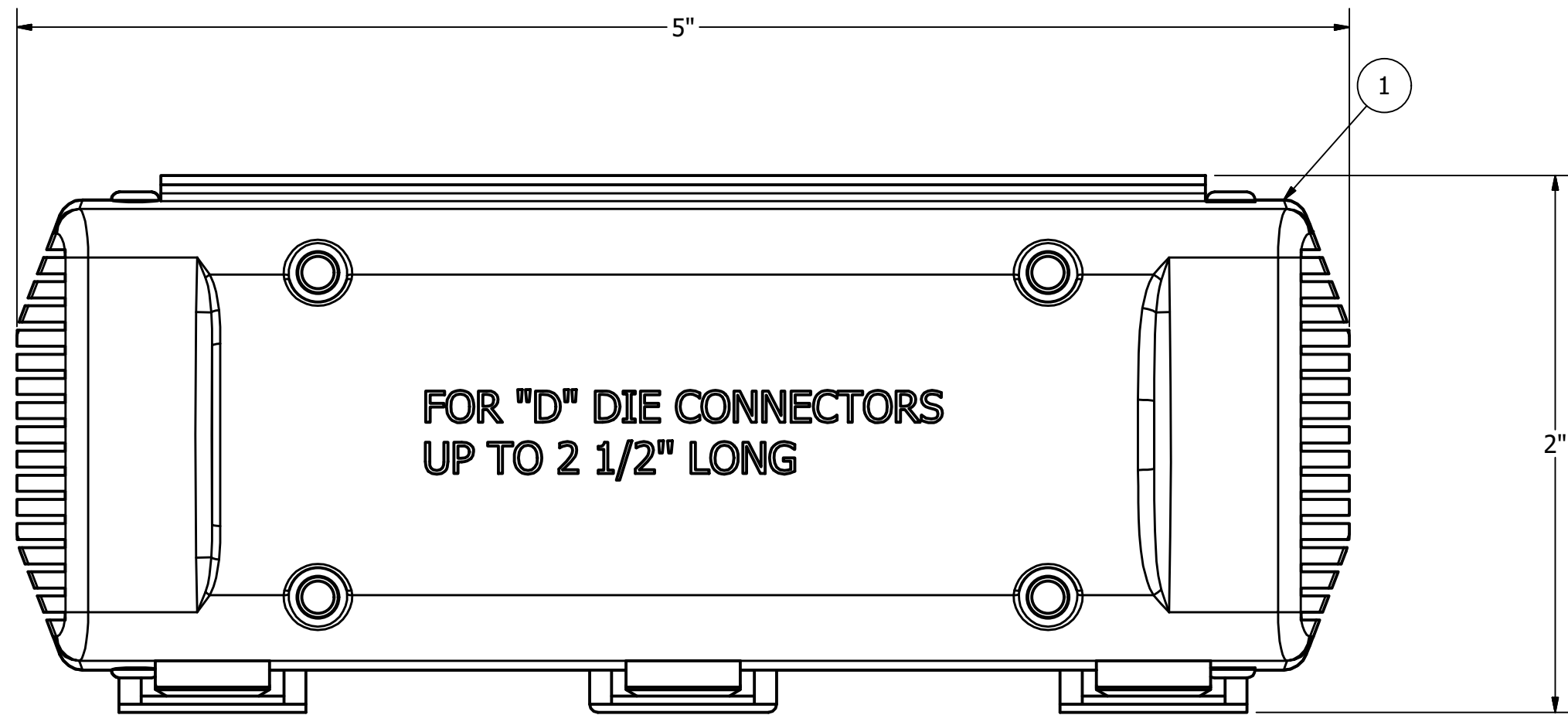

- NOTES:
- ALL DIMENSIONS FOR REFERENCE ONLY. DISTANCE IN. [MM], FORCE LBS. [kN], TORQUE IN. LBS. [N.m], & WEIGHT LBS. [KG].
 - RATINGS:
 - UV RESISTANT
 - CERTIFICATIONS, SPECIFICATIONS, & STANDARDS:
 - NA
 - SUFFIXS & VARIANT CONFIGURATION:
 - NA

79093	07/03/19	HD	RG
EC #	DATE	CHG BY	RESP ENG
DESC OF DWG: INITIAL RELEASE		REASON (S) FOR CHANGE: DISPOSITION OF MAT'L:	

HPS.
CONFIDENTIAL: THIS DRAWING AND ITS CONTENTS ARE CONFIDENTIAL AND THE EXCLUSIVE PROPERTY OF HUBBELL POWER SYSTEMS. NO PUBLICATION, DISTRIBUTION OR COPIES MAY BE MADE WITHOUT THE WRITTEN CONSENT OF HUBBELL POWER SYSTEMS. HUBBELL POWER SYSTEMS UNPUBLISHED ALL RIGHTS RESERVED UNDER THE COPYRIGHT LAWS

HUBBELL® POWER SYSTEMS			
TITLE		PTC	
SNAP TAP™ PLASTIC COVER		PTC2	
SIZE	DWG NO.	CAT / PART / ASSY NO.	REV
C	CC-26127	PTC2	00
DO NOT SCALE THIS DRAWING	DRN BY	SUR	DATE 04/01/2019 SHEET 1 OF 1